

Factsheet HRB

BE 36/08
2008-09-23

HRB Hydrostatic Regenerative Braking system from Rexroth for commercial vehicles and mobile equipment:

Rexroth reduces fuel consumption by up to 25 percent

Initial measurements show that the hydraulic hybrid drive from Rexroth reduces the diesel fuel consumption of heavy commercial vehicles and mobile equipment by up to 25 percent. Emissions from exhaust such as CO₂ are also reduced. The first pilot test vehicle is currently in field testing with the Berlin Department of Sanitation.

Recapturing braking energy

Instead of allowing braking energy to be lost, the HRB Hydrostatic Regenerative Braking system converts it into hydraulic energy and stores it. The next time the vehicle is accelerated this stored energy is fed back to the transmission, thereby unburdening the combustion motor. Rexroth has developed parallel and series HRB systems for the various drive concepts in commercial vehicles and mobile equipment.

Ideal for driving cycles with frequent deceleration and acceleration

The hydraulic hybrid drive from Rexroth demonstrates its full savings potential in heavy vehicles and mobile equipment with frequent braking. The more intensive the start-stop cycle, the greater the possible reduction of fuel consumption using HRB.

Facts at a glance

- Fuel savings of up to 25 percent
- Stores large amounts of braking energy in a short time for virtually complete recovery of the braking energy
- Fast release of the stored energy to the drive train for an efficient support of the primary drive
- Reduced harmful emissions
- Decreased brake wear
- Less fine dust
- Rugged, maintenance-free accumulator
- Can be retrofitted (parallel HRB)
- Lower Total Cost of Ownership
- Better acceleration response and greater driving comfort (no torque interruption while changing gears during acceleration)

Contact for Journalists:
Bosch Rexroth AG
Olaf Marshall
D-89275 Elchingen
Phone: +49 7308 8170-2262
Fax: +49 7308 8170-2683
olaf.marshall@boschrexroth.de

Factsheet HRB

BE 36/08
2008-09-23

HRB parallel relieves load on existing drive motor:

The parallel hybrid drive is designed for vehicles having a conventional mechanical drive train and a combustion engine as the primary drive, such as refuse collection vehicles, school buses and city buses.

A gearbox links a hydraulic variable axial piston unit to the mechanical drive train (drive shaft) to convert kinetic into hydraulic energy when braking. The axial variable piston unit acts here like a pump and converts the released braking energy into hydraulic energy by loading a hydraulic bladder accumulator with hydraulic fluid. This process is controlled by an electronic controller from Rexroth together with a hydraulic valve manifold.

During acceleration the entire process is reversed: The pressurized fluid is discharged in a controlled manner from the accumulator and flows back through the variable axial piston unit. The latter is driven by the fluid flow and, acting like a motor, gives up its energy to the mechanical drive train. A pressure relief valve in the system ensures the highest level of safety for both processes.

A bonus for the vehicle operator: The HRB significantly reduces brake wear. The production of fine dust from brake wear and the CO₂ emissions from the combustion engine are reduced accordingly.

Modular construction means the parallel HRB is be integrated into essentially any commonly available commercial vehicle frame. This also enables retrofitting of existing vehicle fleets.

System components of the parallel HRB:

- A4VSO variable axial piston pump with gearbox for pump/motor operation
- High-pressure bladder accumulator
- HIC valve manifold
- Electronic controller
- Sensors

Practical test at the Berlin City Sanitation Department

Since July 2008 the Berlin City Department of Sanitation has been testing an x2eco series refuse truck built by HALLER Umweltsysteme with a Rexroth parallel hybrid. The New York City Department of Sanitation is also preparing to test an HRB equipped vehicle.

Contact for Journalists:
Bosch Rexroth AG
Olaf Marshall
D-89275 Elchingen
Phone: +49 7308 8170-2262
Fax: +49 7308 8170-2683
olaf.marshall@boschrexroth.de

Factsheet HRB

BE 36/08
2008-09-23

Technical details for the HRB test vehicle

The x2eco series refuse truck from HALLER Umweltsysteme is based on a Mercedes-Benz Actros chassis (empty weight/ permissible total weight approx. 15 / 26 t, diesel motor drive power 235 kW).

Key data for the parallel HRB installed in the test vehicle:

- HRB weight: approx. 500 kg (approx. 1100 lbs)
- HRB power / torque: approx. 250 kW / 2500 Nm
- Accumulator capacity: 2 bladder accumulators each 32 liters gas rated volume
- Maximum accumulator pressure: 330 bar (4800 psi) ; accumulator initial pressure 120 bar (1740 psi)
- Maximum accumulator capacity: 550 kilojoules (corresponds roughly to the kinetic energy of the fully loaded vehicle at 30 km/h / 18.5 mph)
- No retarder function, but can be represented

HRB costs

HRB is based on proven production and near-production components. However, since these are not catalog products, it is not possible to indicate an all-inclusive selling price. The actual added value lies in the combination of these components within the system, i.e. the Rexroth know-how in constructing HRB systems for the respective vehicle class and driving strategy. Depending on these and other vehicle-specific requirements, the (added) price for HRB as part of the respective project situation can be calculated. Vehicle operators demand payback periods of less than four years.

Contact for Journalists:
Bosch Rexroth AG
Olaf Marshall
D-89275 Elchingen
Phone: +49 7308 8170-2262
Fax: +49 7308 8170-2683
olaf.marshall@boschrexroth.de

Factsheet HRB

BE 36/08
2008-09-23

Illustrations HRB parallel:



HRB parallel system components: A4VSO variable axial displacement pump with gearbox, accumulator, accumulator safety valve, HIC valve manifold, electronic controller.
(BE-36-08_HRB-parallel-components-Komponenten.jpg)

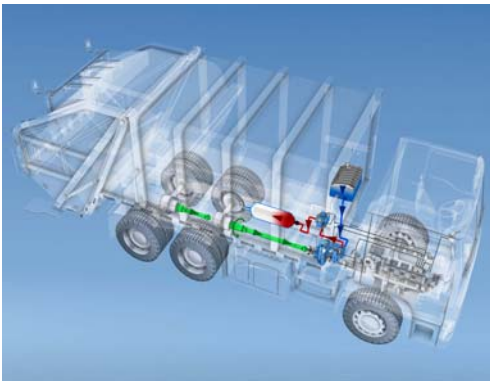

When braking, the variable axial displacement unit converts kinetic into hydraulic energy and pumps hydraulic fluid into an accumulator.
(BE-36-08_HRB-parallel-braking-bremsen.jpg)

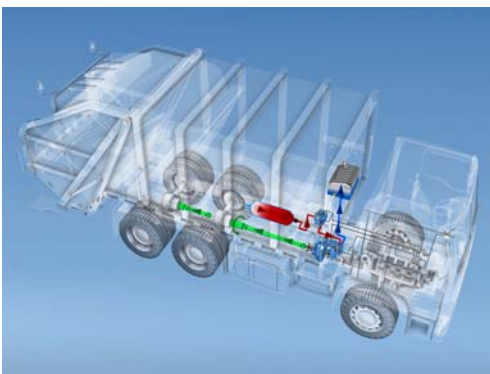

During acceleration the pressurized hydraulic fluid in the accumulator drives the variable axial displacement unit, which then works like a motor.
(BE-36-08_HRB-parallel-accelerating-anfahren.jpg)

Factsheet HRB

BE 36/08
2008-09-23

Bosch Rexroth AG is one of the world's leading specialists in the field of drive and control technologies. Under the brand name of Rexroth the company supplies more than 500,000 customers with tailored solutions for driving, controlling and moving machinery used in industrial and factory automation as well as in mobile applications. As The Drive & Control Company, Bosch Rexroth develops, produces and sells components and systems in more than 80 countries. In 2007 Bosch Rexroth AG, part of the Bosch Group, achieved sales of about 5.4 billion Euro with approximately 33,000 employees.

For more information please visit: www.boschrexroth.com/hrb

Reader Inquiries:

Phone: +49 7308 8170-2262
Fax: +49 7308 8170-2683
E-mail: olaf.marshall@boschrexroth.de
Address : Glockeraustr. 2, D-89275 Elchingen
Internet : www.boschrexroth.com/brm